

## Válvula de Compuerta de 2" - 36" / 150# - 2500# Fig. 333

Material: Acero Carbono / WCB  
 Diseño y fabricación API600, ANSI B16.34  
 Conexión: ANSI B16.10  
 La calificación de Temperatura / Presión ANSI B16.34  
 Prueba de presión API 598

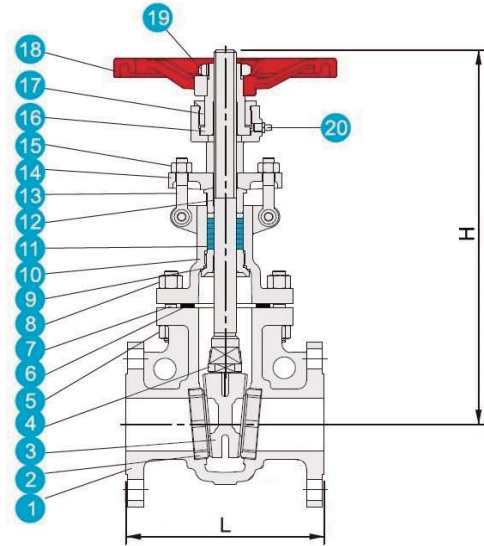

150# / 300# / 600#			
Nº	PARTE	MATERIAL	
1	Cuerpo	A216	WCB
2	Asiento	A216	WCB
3	Disco	A216	WCB
4	Junta	A 182	F6a
5	Tuerca	B 148	A 439
6	Arandela	SS304	GRAFITO
7	Tornillo	A193 Gr.B7	A194 Gr.2H
8	Tuerca	B 148	A 439 Gr.D2
9	Casquillo	SS304	F6A
10	Tapa	A216 Gr. WCB + ER410	
11	Junta Estopada	GRAFITO	
12	Prensaestopa	A 105	
13	Perno Anilla	A193 Gr.B7	A194 Gr.2H
14	Prensaestopa	A105	
15	Tuerca	A193 Gr.B7	A194 Gr.B7
16	Manguito	BRONCE	
17	Tuerca Cierre	A105	
18	Palanca	ACERO AL CARBONO	
19	Junta Tuerca	A 105	
20	Orificio Aceite	BRONCE	



Pulgada	DN	L - 150#	H	L - 300#	H	L - 600#	H
1/2"	15	108	195	140	198	-	-
3/4"	20	117	210	152	215	-	-
1"	25	127	240	165	245	-	-
1 1/4"	32	150	300	178	306	-	-
1 1/2"	40	165	395	190	400	-	-
2"	50	178	400	216	420	292	444
2 1/2"	65	191	435	241	446	330	500
3"	80	203	515	283	537	356	558
4"	100	229	595	305	619	432	665
5"	125	254	725	381	722	508	760
6"	150	267	780	403	806	559	868
8"	200	292	975	419	1000	660	1073
10"	250	330	1150	457	1240	787	1263
12"	300	356	1380	502	1425	838	1600
14"	250	381	1545	762	1585	889	1705
16"	400	406	1733	838	1790	991	1835
18"	450	432	1915	914	1960	1092	-
20"	500	457	2122	991	2458	1194	-
24"	600	508	2520	1143	2576	1397	-
26"	650	559	-	1245	-	-	-
28"	700	610	-	1346	-	-	-
30"	750	610	-	1397	-	-	-
32"	800	711	-	1524	-	-	-
34"	850	762	-	1654	-	-	-
36"	900	711	-	1756	-	-	-

-Nuestra Gama de fabricación incluye 150 # 2500 #, dado que el diseño del cuerpo, la tapa y juntas varían de acuerdo a las condiciones.

-Tenemos Las hojas de datos.